



TSO820 Sampling Oscilloscope, TSO8C17 and TSO8C18 modules Specification and Performance Verification

Register now!
Click the following link to protect your product.
www.tek.com/register

Table of Contents

Important safety information.....	4
General safety summary.....	4
To avoid fire or personal injury.....	4
Service safety summary.....	5
Terms in the manual.....	6
Terms on the product.....	6
Symbols on the product.....	6
Preface	7
Related documents	7
Specifications.....	8
TSO820 mainframe	8
Vertical system.....	8
Signal acquisition system.....	8
Timebase system.....	8
Trigger system.....	8
Clock prescale input trigger operation.....	8
Controls and indicators.....	9
Input and Output communication ports.....	9
Physical characteristics.....	10
Environmental performance.....	10
Waveform measurement.....	10
TSO8C17 and TSO8C18 Specifications.....	11
Optical inputs.....	11
Optical channel inputs.....	11
Physical characteristics	12
Environmental performance.....	12
Performance Verification.....	13
Clock prescale input trigger sensitivity.....	13
Frequency response.....	14
Power monitor accuracy.....	16
Vertical equivalent optical noise.....	18
Output zero (dark level).....	19
TSO820 sampling oscilloscope test records.....	20
Clock prescale input trigger sensitivity test record.....	21
Frequency Response Test Record 12.6 GHz.....	23
Frequency Response Test Record 13.28125 GHz.....	24
Frequency Response Test Record 19.335 GHz.....	25
Frequency Response Test Record 21 GHz.....	26
Frequency Response Test Record 22.5 GHz.....	27
Power monitor accuracy AOP Error test record.....	28
Power monitor accuracy AOP mean test record.....	29
Vertical equivalent optical noise test record.....	30
Output zero (dark level) test record.....	31

Important safety information

This manual contains information and warnings that must be followed by the user for safe operation and to keep the product in a safe condition.

To safely perform service on this product, see the *Service safety summary* that follows the *General safety summary*.

General safety summary

Use the product only as specified. Review the following safety precautions to avoid injury and prevent damage to this product or any products connected to it. Carefully read all instructions. Retain these instructions for future reference.

This product shall be used in accordance with local and national codes.

For correct and safe operation of the product, it is essential that you follow generally accepted safety procedures in addition to the safety precautions specified in this manual.

The product is designed to be used by trained personnel only.

Only qualified personnel who are aware of the hazards involved should remove the cover for repair, maintenance, or adjustment.

Before use, always check the product with a known source to be sure it is operating correctly.

This product is not intended for detection of hazardous voltages.

Use personal protective equipment to prevent shock and arc blast injury where hazardous live conductors are exposed.

While using this product, you may need to access other parts of a larger system. Read the safety sections of the other component manuals for warnings and cautions related to operating the system.

When incorporating this equipment into a system, the safety of that system is the responsibility of the assembler of the system.

To avoid fire or personal injury

Use proper power cord.	Use only the power cord specified for this product and certified for the country of use. Do not use the provided power cord for other products.
Ground the product.	This product is grounded through the grounding conductor of the power cord. To avoid electric shock, the grounding conductor must be connected to earth ground. Before making connections to the input or output terminals of the product, ensure that the product is properly grounded. Do not disable the power cord grounding connection.
Power disconnect.	The power cord disconnects the product from the power source. See instructions for the location. Do not position the equipment so that it is difficult to operate the power cord; it must remain accessible to the user at all times to allow for quick disconnection if needed.
Observe all terminal ratings	To avoid fire or shock hazard, observe all rating and markings on the product. Consult the product manual for further ratings information before making connections to the product. Do not apply a potential to any terminal, including the common terminal, that exceeds the maximum rating of that terminal. Do not float the common terminal above the rated voltage for that terminal. The measuring terminals on this product are not rated for connection to mains or Category II, III, or IV circuits.

Do not operate without covers.	Do not operate this product with covers or panels removed, or with the case open. Hazardous voltage exposure is possible.
Avoid exposed circuitry.	Do not touch exposed connections and components when power is present.
Do not operate with suspected failures.	<p>If you suspect that there is damage to this product, have it inspected by qualified service personnel.</p> <p>Disable the product if it is damaged. Do not use the product if it is damaged or operates incorrectly. If in doubt about safety of the product, turn it off and disconnect the power cord. Clearly mark the product to prevent its further operation.</p> <p>Before use, inspect voltage probes, test leads, and accessories for mechanical damage and replace when damaged. Do not use probes or test leads if they are damaged, if there is exposed metal, or if a wear indicator shows.</p> <p>Examine the exterior of the product before you use it. Look for cracks or missing pieces.</p> <p>Use only specified replacement parts.</p>
Do not operate in wet/damp conditions.	Be aware that condensation may occur if a unit is moved from a cold to a warm environment.
Do not operate in an explosive atmosphere.	
Keep product surfaces clean and dry.	Remove the input signals before you clean the product.
Provide proper ventilation.	<p>Refer to the installation instructions in the manual for details on installing the product so it has proper ventilation.</p> <p>Slots and openings are provided for ventilation and should never be covered or otherwise obstructed. Do not push objects into any of the openings.</p>
Provide a safe working environment.	<p>Always place the product in a location convenient for viewing the display and indicators.</p> <p>Avoid improper or prolonged use of keyboards, pointers, and button pads. Improper or prolonged keyboard or pointer use may result in serious injury.</p> <p>Be sure your work area meets applicable ergonomic standards. Consult with an ergonomics professional to avoid stress injuries.</p> <p>Use care when lifting and carrying the product. This product is provided with a handle or handles for lifting and carrying.</p> <p>Use only the Tektronix rackmount hardware specified for this product.</p> <p>Use only the Tektronix rackmount hardware specified for this product.</p>

Service safety summary

The *Service safety summary* section contains additional information required to safely perform service on the product. Only qualified personnel should perform service procedures. Read this *Service safety summary* and the *General safety summary* before performing any service procedures.

To avoid electric shock	Do not touch exposed connections.
Do not service alone	Do not perform internal service or adjustments of this product unless another person capable of rendering first aid and resuscitation is present.
Disconnect power	To avoid electric shock, switch off the product power and disconnect the power cord from the mains power before removing any covers or panels, or opening the case for servicing.

Use care when servicing with power on

Dangerous voltages or currents may exist in this product. Disconnect power, remove battery (if applicable), and disconnect test leads before removing protective panels, soldering, or replacing components.

Verify safety after repair

Always recheck ground continuity and mains dielectric strength after performing a repair.

Terms in the manual

These terms may appear in this manual:

 WARNING	
	Warning statements identify conditions or practices that could result in injury or loss of life.

 CAUTION	
	Caution statements identify conditions or practices that could result in damage to this product or other property.

Terms on the product





These terms may appear on the product:

- DANGER indicates an injury hazard immediately accessible as you read the marking.
- WARNING indicates an injury hazard not immediately accessible as you read the marking.
- CAUTION indicates a hazard to property including the product.

Symbols on the product

	When this symbol is marked on the product, be sure to consult the manual to find out the nature of the potential hazards and any actions which have to be taken to avoid them. (This symbol may also be used to refer the user to ratings in the manual.)
---	---

The following symbols(s) may appear on the product.

 CAUTION Refer to Manual	 Protective Ground (Earth) Terminal	 Earth Terminal	 Standby
---	--	---	--

Preface

This manual contains specifications, test record, and performance verification procedures for the following instruments:

- TSO820 sampling oscilloscope (mainframe)
- TSO8C17 one channel optical module
- TSO8C18 two channel optical module

Related documents

In addition to this Specifications and Performance Verification Technical Reference, the following documents are available for download. For the most recent versions these documents, visit the Tektronix Web site at www.tek.com/manuals. You can find manuals by searching on the product name and selecting the Manuals filter.

To learn about	Use this document
How to install and turn on the instrument software and hardware; read safety and compliance information.	TSO8 Series Installation and Safety Instructions. Printed and shipped with the instrument. Also available online as a downloadable PDF. This document contains content in English, Japanese, and Simplified Chinese.
How to operate the instrument, take measurements, navigate the UI.	TSO8 Series Help (a PDF of this Help is available as a downloadable PDF)
How to remotely control the instrument using programmatic commands. Syntax provided.	TSO8 Series Programming Manual
Mainframe and module specifications. Includes procedures to verify that the mainframe and modules meet warranted specifications.	TSO8 Series Specifications and Performance Verification Technical Reference (this document)
Installing up to two mainframes, or a mainframe and a TCR801 clock recovery unit into a standard instrument rack using the rackmount kit.	TSO8 Series Rackmount Instructions
How to declassify, sanitize, and clear memory devices in the instrument.	TSO8 Series Declassification and Security Instructions

Specifications

TSO820 mainframe

Vertical system

Rise time / bandwidth	Determined by the sampling modules used
Vertical resolution (nominal)	15.6 bits over the sampling modules' dynamic range

Signal acquisition system

Number of input channels	4 user channels acquisition maximum
Number of slots	2 slots, 2 channels per slot, for 4 channels total
Vertical resolution	15.6 bits at Tek Probe-Sampling interface

Timebase system

Main time base / horizontal scale	1 ps / div to 1 ms / div in 1-2-5 sequence or 1 ps increments
Horizontal modes	Supports Free Run Trigger and Clock Trigger mode
Clock trigger mode sampling rate	200 kHz – 300 kHz, dictated by sample resolution of Time Base setup
Horizontal position range	<ul style="list-style-type: none"> 19 ns minimum to 50 ms maximum; depends upon the reference clock frequency (refClkFreq) per the formula: $\text{maxTimeOfFirstPoint} = \frac{1}{\text{refClkFreq}} \times 2^{16}$ Horizontal position reference can change within the record, so the maximum horizontal position value depends upon the horizontal scale as well.
Horizontal position setting resolution	10 fs minimum
Record length	<ul style="list-style-type: none"> Pattern Sync is Off: 1000 to 838,860,700 Pattern Sync is On: 762 to 838,860,700
Horizontal sample resolution	10 fs minimum to 10 μ s maximum
Time interval accuracy, Clock triggered mode (typical)	\pm (1 ps + 1.5 % of trigger clock period)

Trigger system

Trigger sources	Supports the following for trigger source: <ul style="list-style-type: none"> Clock Prescale Input Free Run Trigger
-----------------	---

Clock prescale input trigger operation

Clock prescale input characteristics	50 Ω , AC coupled
Clock prescale input pattern lengths supported	127 to $2^{23} - 1$ (8,388,607) inclusive

Clock prescale input absolute maximum input	2.0 Vp-p
Clock prescale input usable frequency range	500 MHz - 32 GHz
Clock prescale input range	200 mVp-p to 1000 mVp-p over the range 500 MHz - 32 GHz
Clock prescale input jitter	500 MHz to 2 GHz: < 1530 fs RMS (sinusoidal trigger waveform; typical square-wave performance similar to below values) 2 to 3 GHz: < 600 fsRMS 3 to 9 GHz: < 580 fsRMS 9 to 32 GHz: < 500 fsRMS

Controls and indicators

Display type	61 mm (W) x 12 mm (H), 2 x 20 liquid crystal display (LCD)
Display resolution	5 (W) x 8 (H) pixels per alphanumeric character
Background color	White
Move display cursor Left, Right, Up, Down, Select	Keypad buttons to move display cursor and select selections. Blue backlit keys.
Power button	Powers unit on/off. Blue LED indicates power is On. Amber LED indicates power is Off (in standby mode). To completely power off, unplug unit from power source.
Control interface	IEEE 100BASE-T, 1000BASE-T; RJ45 connector
Device information	Instrument serial number, software version, other available using TSOVu

Input and Output communication ports

Gigabit ethernet	IEEE 802.3™ 100BASE-T/1000BASE-T
USB 3.0	USB port used for software updates via USB Flash drives only.

Front panel

Anti-static protection connector	Banana-jack connector, 1 MΩ to chassis ground
---	---

Rear panel

Ethernet port	RJ45 connector; supports IEEE 802.3™ Ethernet 100/1000BASE-T
----------------------	--

Physical characteristics

Weight (with blank module)	<ul style="list-style-type: none"> 12.0 lbs (5.4 kg) Stand-alone instrument, without front cover. 19.5 lbs (8.8 kg) Instrument with rackmount, without front cover.
Clearance requirements	The clearance requirement for adequate cooling is 2.0 in (50.8 mm) on both sides and at the rear of the instrument. Cooling inlets on the bottom require that the instrument rests on a flat surface with feet providing sufficient clearance.
Overall dimensions	TSO820 (with filler module, no functional modules) requirements that follow are nominal and unboxed:

Height	132 mm (5.18 in.)
Width	217 mm (8.56 in.)
Depth	590 mm (23.22 in.)

Environmental performance

Temperature	<ul style="list-style-type: none"> Operating: 5 °C to +45 °C, with 15 °C/hour maximum gradient, non-condensing, derated 1.0 °C per 300 meters above 1,500 meters altitude. Non-operating: -20 °C to +60 °C, with 30 °C/hour maximum gradient
Altitude	<ul style="list-style-type: none"> Operating: Up to 3,000 meters, derate maximum operating temperature by 1 °C per 300 meters above 1,500 meters altitude. Non-operating: Up to 12,000 meters
Humidity	<ul style="list-style-type: none"> Operating: 5% to 95% RH (relative humidity) at up to +30 °C, 5% to 45% RH above +30 °C up to +45 °C, non-condensing Non-operating: 5% to 95% RH (relative humidity) at up to +30 °C, 5% to 45% RH above +30 °C up to +60 °C, non-condensing

Waveform measurement

System measurement rate	Supports up to 32 simultaneous measurement with optional display of per-measurement statistics (min, max, mean and standard deviation)
Cursors	Vertical bar, horizontal bar, vertical and horizontal bar, and waveform cursors
Waveform processing Bandwidth Enhancement/Impulse Response Correction (BWE)	TDECQ equalized waveform
Histograms	Supports up to 30 histograms on multiple windows
Pulse measurements (built-in)	High, Low, Amplitude, Max, Min, Mid, Mean, Peak-Peak, Period, Frequency, Rise, Fall, Positive Cross, Negative Cross, Positive Width, Negative Width, RMS Jitter, Pk-Pk Jitter, Delay
PAM4 measurements (optional)	RLM, Level, Level Deviation, Level Thickness, OMAouter, Extinction Ratio, ES Levels, Eye Width, Eye Height, Transition Time, Overshoot, Undershoot, TDECQ

TSO8C17 and TSO8C18 Specifications

Optical inputs

Optical channel count	<ul style="list-style-type: none"> • TSO8C17: One optical channel • TSO8C18: Two optical channels
Wavelength range (typical)	750 nm to 1650 nm
Calibrated wavelength (± 20 nm)	850 nm, 1310 nm, and 1550 nm
Fiber input	50 / 125 μ m multi-mode type
Typical mask test sensitivity: 100GBASE-LR4	-14 dBm at 1310 nm
Unfiltered optical bandwidth	<ul style="list-style-type: none"> • Multi-mode: 30 GHz • Single mode: 30 GHz
Optical return loss	<ul style="list-style-type: none"> • Multi-mode: > 16 dB • Single mode: > 16 dB

Optical channel inputs

Optical power meter range	-38 dBm to +6 dBm at 1310 nm
Mainframe display vertical scale factors	<ul style="list-style-type: none"> • Maximum: 350 μW/div • Minimum: 3.5 μW/div
Channel delay range	± 65 ps
Output zero (dark level)	< 10 μ W ± 4 % (vertical offset)
Vertical offset range	± 2.25 mW offset
DC vertical accuracy	± 10 μ W ± 5 % of vertical reading
Power meter accuracy	$\pm [100$ nW + (External power meter reading)] * [5% + 6% Uncertainty]

RMS optical noise (hardware; typical)

Bandwidth	850 nm	1310 nm	1550 nm
12.6 GHz	4.2 μ W	2.8 μ W	3.0 μ W
13.28125 GHz	4.3 μ W	2.9 μ W	3.0 μ W
19.335 GHz	5.3 μ W	3.7 μ W	3.9 μ W
21 GHz	6.2 μ W	4.2 μ W	4.4 μ W
22.5 GHz	8.1 μ W	5.0 μ W	5.4 μ W

RMS optical noise (hardware; maximum)

Bandwidth	850 nm	1310 nm	1550 nm
12.6 GHz	6 μ W	3.6 μ W	3.9 μ W
13.28125 GHz	6 μ W	3.6 μ W	3.9 μ W
19.335 GHz	7.5 μ W	4.5 μ W	4.8 μ W
21 GHz	8.3 μ W	5.0 μ W	5.4 μ W
22.5 GHz	11.1 μ W	6.7 μ W	6.9 μ W

Supported optical reference receivers

TSO8C17 and TSO8C18	PAM2 / NRZ	PAM4
	25.78 GBd (TDEC-MM)	26.5625 GBd Single-mode and multi-mode standards of the IEEE 802.3™ (E.g. BWel 13.28125 GHz)
	25.78 GBd	
	27.95 GBd	53.125 GBd standards of the IEEE 802.3™ (E.g. BWel 26.5625 GHz)
	28.05 GBd	

Front panel optical fiber connectors

FC/PC bulk head receptacle

Physical characteristics

Dimensions

Height	2.1 in. (53 mm)
Width	3.76 in. (96 mm)
Depth	10.35 in. (263 mm)

Weight

TSO8C17	1.21 lbs. (0.549 kg)
TSO8C18	1.46 lbs. (0.660 kg)

Environmental performance

Temperature

- **Operating:** 5 °C to +45 °C, with 15 °C/hour maximum gradient, non-condensing, derated 1.0 °C per 300 meters above 1,500 meters altitude.
- **Non-operating:** -20 °C to +60 °C, with 30 °C/hour maximum gradient

Altitude

- **Operating:** Up to 3,000 meters, derate maximum operating temperature by 1 °C per 300 meters above 1,500 meters altitude.
- **Non-operating:** Up to 12,000 meters

Humidity

- **Operating:** 5% to 95% RH (relative humidity) at up to +30 °C, 5% to 45% RH above +30 °C up to +45 °C, non-condensing
- **Non-operating:** 5% to 95% RH (relative humidity) at up to +30 °C, 5% to 45% RH above +30 °C up to +60 °C, non-condensing

Performance Verification

Clock prescale input trigger sensitivity

Apply sinusoid from synthesizer through a 6 dB passive coupler, splitting the signal between the clock prescale input and a calibrated power meter. Compare the measured clock prescale frequency with the nominal test frequencies, stepped from 1 GHz to 32 GHz in 1 GHz increments, and including 500 MHz.

Required equipment

Equipment	Example
Mainframe (Sampling oscilloscope)	Tektronix TSO820
Optical sampling module	Tektronix TSO8C17 or TSO8C18
40 GHz synthesizer generator	Anritsu MG3694C
6 dB power splitter	Anritsu K241C
Power meter with remote sensor	R&S NRX Power Meter with NRP-Z85.02 Remote Sensor

Test setup

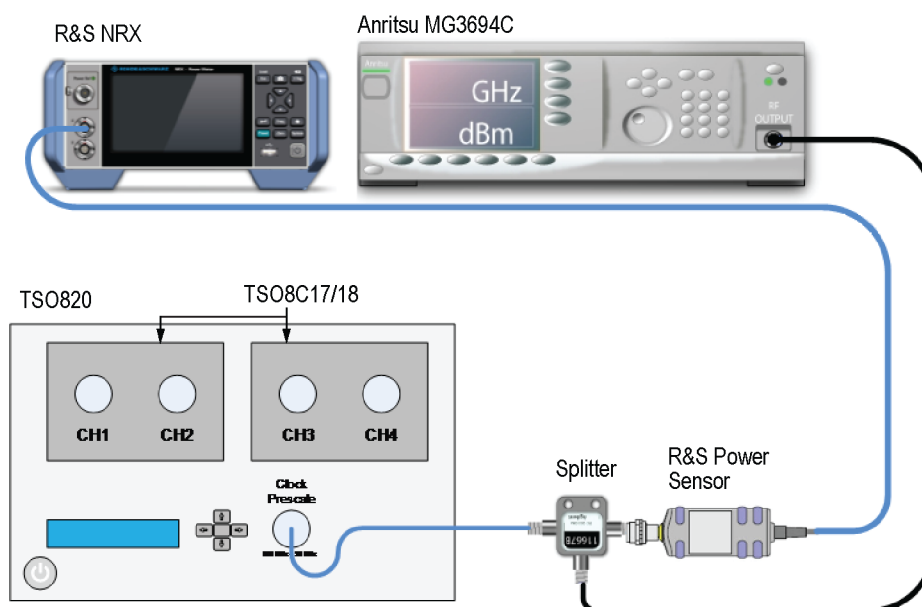

Figure 1: Clock prescale input trigger sensitivity setup

Procedure

1. Connect the synthesized generator output to a 6 dB splitter, splitting the signal between the clock prescale input and power meter.
2. In TSOVu, set the Trigger source to clock prescale input.
3. Set the synthesized generator frequency to 500 MHz and power level equivalent to 200 mVp-p (-10 dBm).
4. Set the TSOVu symbol rate to 500 MHz.
5. Retrieve the Trigger clock prescale frequency.
6. Verify the frequency is within 0.5 % of the set value. This verifies the minimum trigger level.
7. Repeat steps 4-6 for frequency settings from 1 GHz - 32 GHz in 1 GHz steps.
8. Set the synthesized generator to 500 MHz and power level equivalent to 1 Vp-p (3.98 dBm) at the User clock input.
9. Retrieve the Trigger clock prescale frequency.

10. Verify the frequency is within 0.5 % of the set value. This verifies the maximum trigger level.
11. Repeat steps 8-10 for frequency settings from 1 GHz - 32 GHz in 1 GHz step intervals.

Frequency response

Verification of the reference receiver response and optical bandwidth using the impulse method.

Required equipment

Equipment	Example
Mainframe (Sampling oscilloscope)	Tektronix TSO820
Optical sampling module	Tektronix TSO8C17 or TSO8C18
Optical attenuator	OZ Optics BB-100-11-850-5/125-S-40-3S3S-3-0.1
Impulse laser	Calmar Mendocino 1550 nm impulse laser with 10 GHz synchronous clock output and 20 MHz repetition rate
Impulse laser	Calmar Mendocino 850 nm impulse laser with 10 GHz synchronous clock output and 20 MHz repetition rate

Test setup

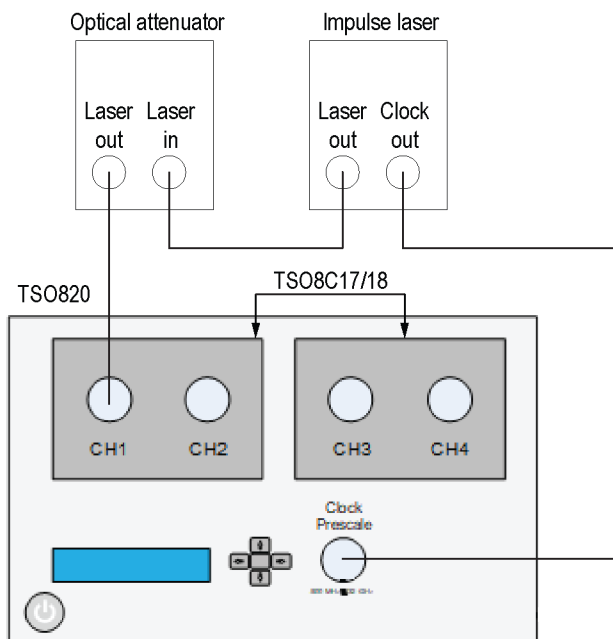

Figure 2: Frequency response test setup

Connect either the 1550 nm or 850 nm impulse laser through an attenuator to the Unit Under Test (UUT) input.

Procedure

Set the impulse up on the module, retrieve the data and calculate the bandwidth or compare the frequency response to the Optical Reference Receiver (ORR).

1. Setup the oscilloscope horizontal settings
 - a. Pattern Sync: On
 - b. Symbol Rate: 10 GBd
 - c. Samples / UI: 100
 - d. Data Clock Ratio: 1:1

- e. Pattern Length: 500
 - f. Trigger Source: Clock Prescale Input
 - g. Acquisition: Sample
2. Set optical attenuator to ~36 dB.
3. Connect the 1550 nm optical signal from the impulse laser through the optical attenuator to the optical channel under test.
4. Connect the 10 GHz synchronous clock signal to the clock prescale input.
5. In the Optical Settings menu, select the correct wavelength for the optical source being used.
 - a. Select Filter Type: Hardware Filter
 - b. Select BW Electrical: 12.6 GHz, 13.28125 GHz, 19.335 GHz, or 21 GHz
6. Start acquiring.
7. Adjust the optical attenuator until the impulse is between 500 μ W and 1 mW peak amplitude.
8. Set Acquisition to 32 Averages.
9. Acquire averaged waveform and retrieve the curve data.
10. Create a 50 ns rectangular window around the impulse, with the impulse peak located approximately 5 ns from the left side of the window.
11. Calculate the mean value of all curve data outside of the 50 ns window and subtract this mean value from the windowed data.
12. Perform a Discrete Fourier Transform (DFT) on the windowed data. The DFT data will have 200 MHz spacing in the frequency domain with a Nyquist frequency of 500 GHz.
13. Compare the magnitude response of the DFT to the ORR tolerances for the filter being used. If checking the 22.5 GHz filter, then verify that the 3 dB optical bandwidth is > 30 GHz.
14. Repeat steps 5-15 for all bandwidth settings.
15. Repeat steps 2-16 with the 850 nm source.
16. Connect Optical signal from the Optical attenuator output to next sampling oscilloscope optical channel input and repeat steps 2-17 until all populated channels are tested.

Power monitor accuracy

Verify the accuracy of the AOP (Average Optical Power) and Mean measurement of the UUT by comparing the measurement to an external optical power meter.

Required equipment

Equipment	Example
Mainframe (Sampling oscilloscope)	Tektronix TSO820
Optical sampling module	TSO8C17 or TSO8C18
1550 nm Optical source	OZ Optics HIFOSS-01-3S-9/125-1550-S-30
1310 nm Optical source	OZ Optics HIFOSS-01-3S-9/125-1310-S-30
850 nm Optical source	OZ Optics HIFOSS-01-3S-9/125-850-S-30-SP
Optical attenuator	OZ Optics BB-100-11-850-5/125-S-40-3S3S-3-0.1
Optical power meter	Yokogawa AQ2200-212

Test setup

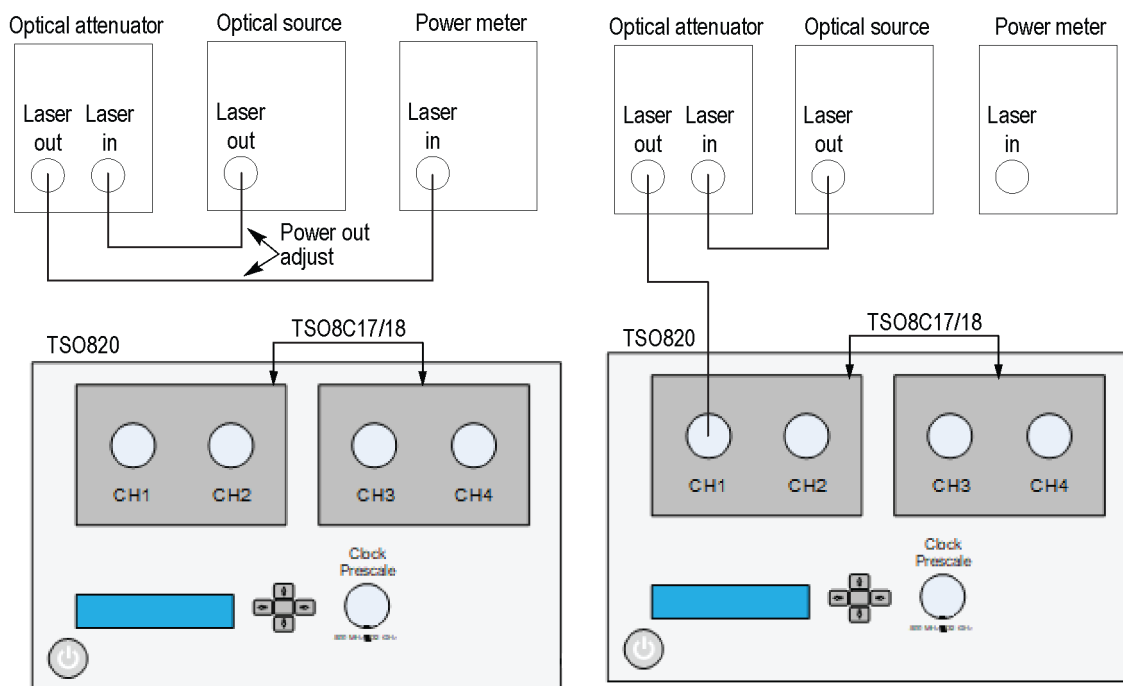

Figure 3: Power adjust test setup

Figure 4: Power monitor accuracy test setup

Apply either 1550 nm, 1310 nm, or 850 nm at 200 μ W signal to the attenuator, then to the power meter. Use the optical attenuator to adjust the power level to 200 μ W, then change the output of the attenuator to the sampling oscilloscope optical input channel under test.

Procedure

The signal is measured using the optical module AOP. The AOP measurement is then compared to the external optical power meter reading. A mean waveform measurement is also used and is compared to the AOP measurement.

1. Perform mainframe and channel compensation prior to test.
2. Setup oscilloscope Trigger and Acquisition settings.

- a. Record length: 25000
- b. Horizontal scale: 1 ns/div
- c. Trigger source: Free Run
- d. Acquisition: Average
- e. Stop after 16 Averages
3. Apply the signal from 1310 nm source to the external optical power meter.
4. Set the optical channel wavelength to 1310 nm.
5. Set the bandwidth electrical to 21 GHz.
6. Adjust the power level to 200 μ W using the attenuator.
7. Record the external optical power meter measurement as Inputpower.
8. Apply the signal to the optical channel under test.
9. Record the mean measurement as UUTMean.
10. Record the AOP measurement as UUTAOP.
11. Calculate the AOP % error and the Mean % error.

$$\%ErrorAOP = \frac{UUTAOP - Inputpower}{Inputpower} \times 100$$

$$\%Errormean = \frac{UUTMean - Inputpower}{Inputpower} \times 100$$

12. Return % Error AOP and % Error mean and compare to ± 5 % specification.
13. Repeat steps 3-12 for all other wavelength settings.
14. Repeat all steps until all populated channels are tested.

Vertical equivalent optical noise

For each bandwidth setting a vertical histogram is used to measure the vertical RMS noise.

This test measures the UUTs vertical equivalent optical noise for all bandwidths and wavelength settings. It is very important that no stray light be allowed to enter the DUT during this test as it will affect the measurement. Additionally the optical module under test and the oscilloscope must have been compensated within a recent time (See the compensation test method for more information). The noise is measured using a vertical histogram. The vertical scale must be set to the minimum that can be allowed and not lose any points off the screen, because the histogram accuracy depends on the rasterized waveform vertical resolution.

Required equipment

TSO820 with TSO8C17 or TSO8C18 optical sampling module

Test setup

Noise is measured with the system triggered in Free Run and the optical inputs capped. Measurements are made at all channel wavelength and bandwidth settings.

Procedure

1. Remove any optical signal fiber from the UUT and place a light blocking cap over the input.
2. Compensate the channel.
3. Set the oscilloscope to trigger in Free run mode and set Acquisition mode to sample, stop after 4 Acquisition.
4. Set the Horizontal Scale to 100 ps/div, Record Length to 16384.
5. Setup the histogram.
 - a. Set mode to vertical.
 - b. Set the source to the channel being tested.
 - c. Setup the histogram to cover the entire screen.
6. Choose the bandwidth and wavelength setting to be measured.
7. Turn on the display of the channel under test, and set the vertical scale as low as possible such there are no potential histogram hits occurring off screen.
8. Click Set Persist Data to On and set Persistence to Infinite for the channel being tested.
9. Start the oscilloscope acquisition.
10. Wait for the acquire condition to be met.
11. Record the histogram standard deviation and check against the noise specification for this bandwidth and wavelength setting.

Table 1: Noise specification

Bandwidth (GHz)	850 nm RMS Noise (μ W)	1310 nm RMS Noise (μ W)	1550 nm RMS Noise (μ W)
12.6 GHz	6	3.6	3.9
13.28125 GHz	6	3.6	3.9
19.335 GHz	7.5	4.5	4.8
21 GHz	8.3	5.0	5.4
22.5 GHz	11.1	6.7	6.9

12. Repeat steps 7-10 for all bandwidth and wavelength settings.
13. Repeat steps 1 -12 for all populated channels.

Output zero (dark level)

Measure the mean value of the signal when no input is applied. Check all bandwidth and filter settings.

Required equipment

TSO820 with optical sampling module

Test setup

Dark level is measured with the system triggered in Free Run and the optical inputs capped. Measurements are made at all channel wavelength and bandwidth settings. Compensation on the channel under test must have been run recently with no change in ambient temperature greater than 1 °C occurring in between compensation and the dark level test.

Procedure

1. Remove any optical signal fiber from the UUT and place a light blocking cap over the input.
2. Set the oscilloscope to trigger in Free Run mode.
3. Compensate the channel.
4. Set Vertical offset to 0 mW for the channel under test.
5. Set the Acquisition mode to Average, Stop after 32 Averages.
6. Set the Horizontal Scale to 1 ns/div, Record Length to 25000.
7. Choose the bandwidth and wavelength setting to be measured.
8. Turn on the display of the channel under test.
9. Add a Mean measurement for to the channel under test.
10. Start the oscilloscope acquisition and record the Mean measurement after the stop condition has been met.
11. Mean measurement should be within the specified limits.
12. Set vertical offset to 1.4 mW and repeat steps 4-10.
13. Repeat steps 10 - 12 for all bandwidth and wavelength settings.
14. Repeat steps 1 -13 for all populated channels.

TSO820 sampling oscilloscope test records

This section contains test records that you can use to record the results of your performance verification checks.

Do not enter values into the records contained in this manual; rather, make copies of the records and enter test results on the copies.

The test records provide entries for all checks found in the Performance Tests procedures.

For each channel tested, photocopy this and the next page, and record the performance test results for the main-instrument test record.

Clock prescale input trigger sensitivity test record

Test: Clock prescale input trigger sensitivity

Instrument serial number:

Certificate number:

Date of calibration:

Technician:

Test record channel: (1-4)

Frequency (GHz)	Minimum	Frequency measured (GHz)	Maximum	Frequency measured (GHz)
0.5	200 mV		1000 mV	
1	200 mV		1000 mV	
2	200 mV		1000 mV	
3	200 mV		1000 mV	
4	200 mV		1000 mV	
5	200 mV		1000 mV	
6	200 mV		1000 mV	
7	200 mV		1000 mV	
8	200 mV		1000 mV	
9	200 mV		1000 mV	
10	200 mV		1000 mV	
11	200 mV		1000 mV	
12	200 mV		1000 mV	
13	200 mV		1000 mV	
14	200 mV		1000 mV	
15	200 mV		1000 mV	
16	200 mV		1000 mV	
17	200 mV		1000 mV	
18	200 mV		1000 mV	
19	200 mV		1000 mV	
20	200 mV		1000 mV	
21	200 mV		1000 mV	
22	200 mV		1000 mV	
23	200 mV		1000 mV	
24	200 mV		1000 mV	
25	200 mV		1000 mV	
26	200 mV		1000 mV	
27	200 mV		1000 mV	

Table continued...

Frequency (GHz)	Minimum	Frequency measured (GHz)	Maximum	Frequency measured (GHz)
28	200 mV		1000 mV	
29	200 mV		1000 mV	
30	200 mV		1000 mV	
31	200 mV		1000 mV	
32	200 mV		1000 mV	

Frequency Response Test Record 12.6 GHz

Test: Frequency response at 12.6 GHz

Instrument serial number:

Certificate number:

Date of calibration:

Technician:

Test record channel: (1-4)

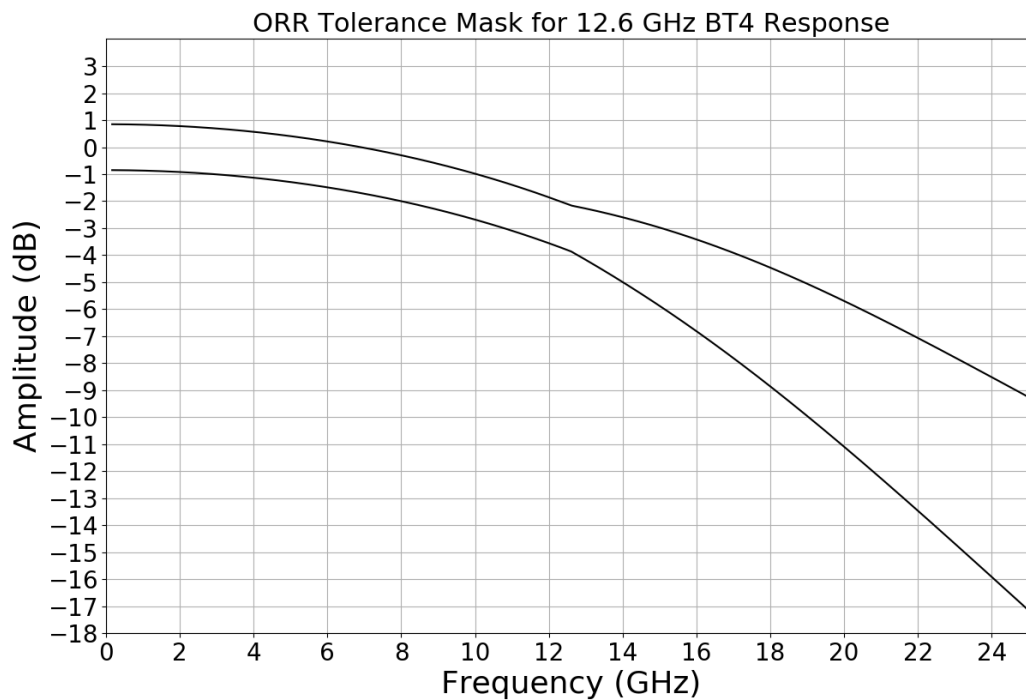

Frequency (GHz)	Amplitude (dB)	Frequency (GHz)	Amplitude (dB)	Frequency (GHz)	Amplitude (dB)
1		11		21	
2		12		22	
3		13		23	
4		14		24	
5		15		25	
6		16			
7		17			
8		18			
9		19			
10		20			

Frequency Response Test Record 13.28125 GHz

Test: Frequency response at 13.28125 GHz

Instrument serial number:

Certificate number:

Date of calibration:

Technician:

Test record channel: (1-4)

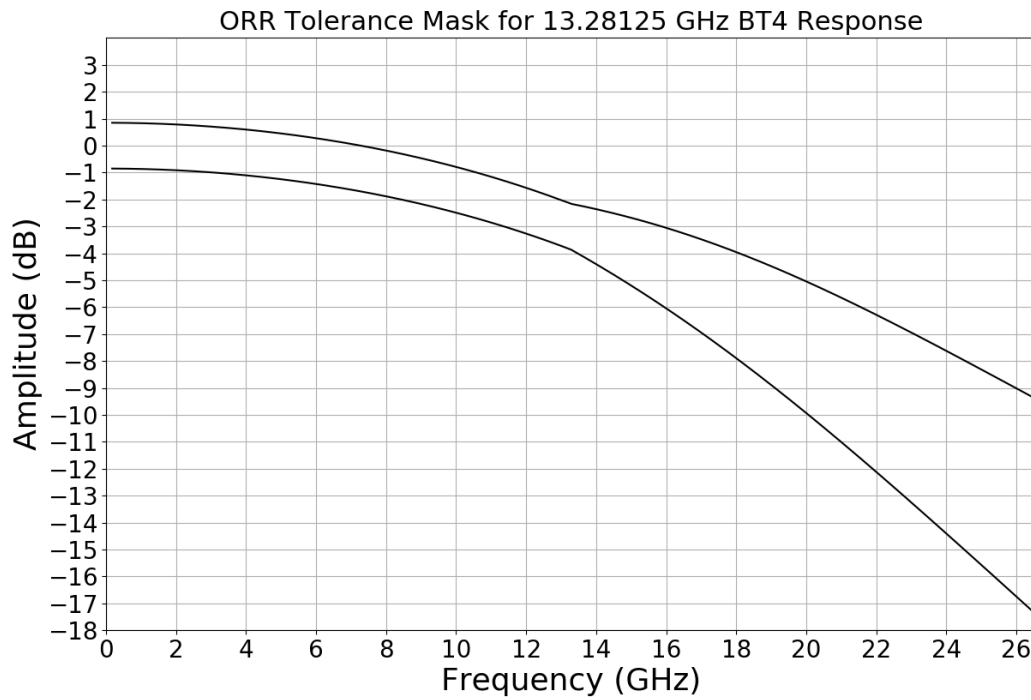

Frequency (GHz)	Amplitude (dB)	Frequency (GHz)	Amplitude (dB)	Frequency (GHz)	Amplitude (dB)
1		11		21	
2		12		22	
3		13		23	
4		14		24	
5		15		25	
6		16		26	
7		17			
8		18			
9		19			
10		20			

Frequency Response Test Record 19.335 GHz

Test: Frequency response at 19.335 GHz

Instrument serial number:

Certificate number:

Date of calibration:

Technician:

Test record channel: (1-4)

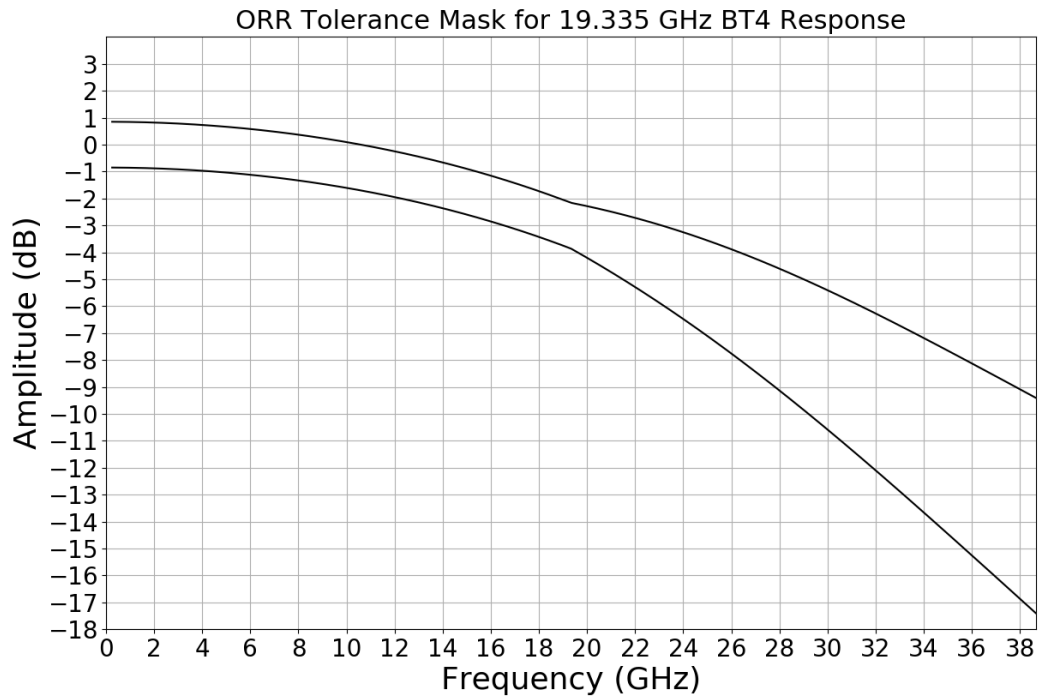

Frequency (GHz)	Amplitude (dB)	Frequency (GHz)	Amplitude (dB)	Frequency (GHz)	Amplitude (dB)	Frequency (GHz)	Amplitude (dB)
1		11		21		31	
2		12		22		32	
3		13		23		33	
4		14		24		34	
5		15		25		35	
6		16		26		36	
7		17		27		37	
8		18		28		38	
9		19		29			
10		20		30			

Frequency Response Test Record 21 GHz

Test: Frequency response at 21 GHz

Instrument serial number:

Certificate number:

Date of calibration:

Technician:

Test record channel: (1-4)

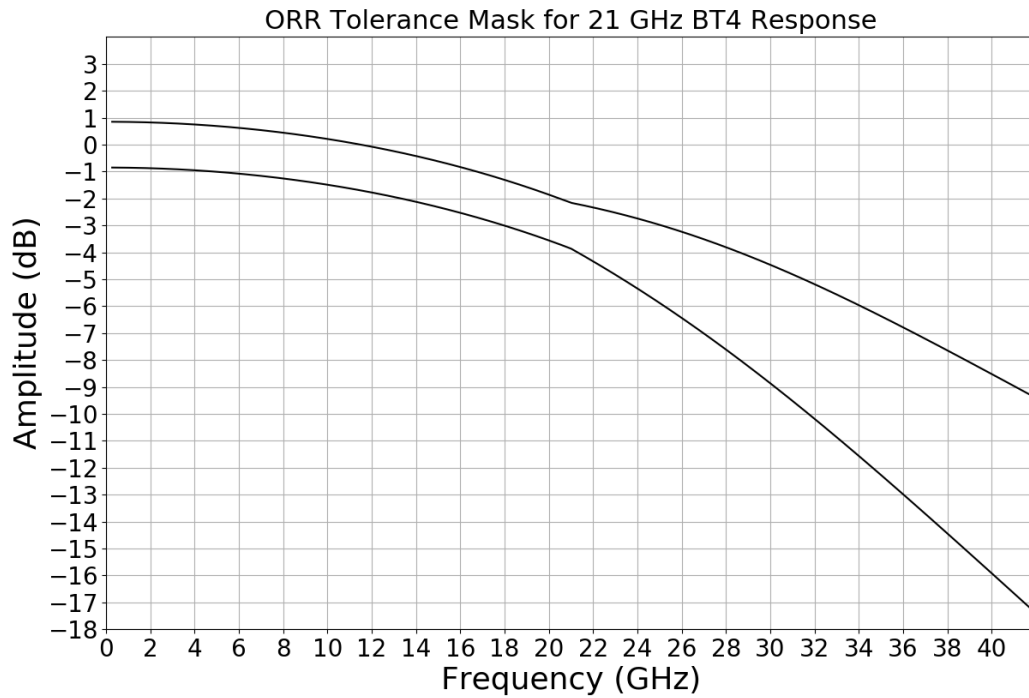

Frequency (GHz)	Amplitude (dB)	Frequency (GHz)	Amplitude (dB)	Frequency (GHz)	Amplitude (dB)	Frequency (GHz)	Amplitude (dB)
1		11		21		31	
2		12		22		32	
3		13		23		33	
4		14		24		34	
5		15		25		35	
6		16		26		36	
7		17		27		37	
8		18		28		38	
9		19		29		39	
10		20		30		40	

Frequency Response Test Record 22.5 GHz

Test: Frequency response at 22.5 GHz

Instrument serial number:

Certificate number:

Date of calibration:

Technician:

Test record channel: (1-4)

BW @ 30GHz : _____ GHz

Power monitor accuracy AOP Error test record

Test: Power monitor accuracy (AOP Error)

Instrument serial number:

Certificate number:

Date of calibration:

Technician:

Test record channel: (1-4)

Wavelength	Bandwidth setting	Minimum	AOP Error %	Maximum
1550 nm	22.5 GHz	-5%		+5%
	21 GHz	-5%		+5%
	19.335 GHz	-5%		+5%
	13.28125 GHz	-5%		+5%
	12.6 GHz	-5%		+5%
1310 nm	22.5 GHz	-5%		+5%
	21 GHz	-5%		+5%
	19.335 GHz	-5%		+5%
	13.28125 GHz	-5%		+5%
	12.6 GHz	-5%		+5%
850 nm	22.5 GHz	-5%		+5%
	21 GHz	-5%		+5%
	19.335 GHz	-5%		+5%
	13.28125 GHz	-5%		+5%
	12.6 GHz	-5%		+5%

Power monitor accuracy AOP mean test record

Test: Power monitor accuracy (AOP Mean)

Instrument serial number:

Certificate number:

Date of calibration:

Technician:

Test record channel: (1-4)

Wavelength	Bandwidth setting	Minimum	AOP Mean %	Maximum
1550 nm	22.5 GHz	-5%		+5%
	21 GHz	-5%		+5%
	19.335 GHz	-5%		+5%
	13.28125 GHz	-5%		+5%
	12.6 GHz	-5%		+5%
1310 nm	22.5 GHz	-5%		+5%
	21 GHz	-5%		+5%
	19.335 GHz	-5%		+5%
	13.28125 GHz	-5%		+5%
	12.6 GHz	-5%		+5%
850 nm	22.5 GHz	-5%		+5%
	21 GHz	-5%		+5%
	19.335 GHz	-5%		+5%
	13.28125 GHz	-5%		+5%
	12.6 GHz	-5%		+5%

Vertical equivalent optical noise test record

Test: Vertical equivalent optical noise

Instrument serial number:

Certificate number:

Date of calibration:

Technician:

Test record channel: (1-4)

Wavelength	Bandwidth setting	Noise ($\mu\text{W RMS}$)	Maximum
1550 nm	22.5 GHz		6.9
	21 GHz		5.4
	19.335 GHz		4.8
	13.28125 GHz		3.9
	12.6 GHz		3.9
1310 nm	22.5 GHz		6.7
	21 GHz		5
	19.335 GHz		4.5
	13.28125 GHz		3.6
	12.6 GHz		3.6
850 nm	22.5 GHz		11.1
	21 GHz		8.3
	19.335 GHz		7.5
	13.28125 GHz		6
	12.6 GHz		6

Output zero (dark level) test record

Test: Output zero (dark level)

Instrument serial number:

Certificate number:

Date of calibration:

Technician:

Test record channel:

Wavelength	Bandwidth setting	Minimum	Output zero (μW)	Maximum
1550 nm	22.5 GHz	-10 μW		+10 μW
	21 GHz	-10 μW		+10 μW
	19.335 GHz	-10 μW		+10 μW
	13.28125 GHz	-10 μW		+10 μW
	12.6 GHz	-10 μW		+10 μW
1310 nm	22.5 GHz	-10 μW		+10 μW
	21 GHz	-10 μW		+10 μW
	19.335 GHz	-10 μW		+10 μW
	13.28125 GHz	-10 μW		+10 μW
	12.6 GHz	-10 μW		+10 μW
850 nm	22.5 GHz	-10 μW		+10 μW
	21 GHz	-10 μW		+10 μW
	19.335 GHz	-10 μW		+10 μW
	13.28125 GHz	-10 μW		+10 μW
	12.6 GHz	-10 μW		+10 μW